

Reduction of deadweight pendulum motion and its conformation by using a build-up system[†]

Yon-Kyu Park^{*}, Dae-Im Kang, Jong-Ho Kim and Min-Seok Kim

Division of Physical Metrology, Korea Research Institute of Standards and Science(KRIS), Daejeon 305-340, Korea

(Manuscript Received June 4, 2007; Revised January 29, 2009; Accepted August 3, 2009)

Abstract

Deadweight force machines cause oscillating components strongly related to the pendulum motion of the deadweight in the measured force signals. An estimating method of the pendulum motion using a build-up system has been proposed in previous papers. In this paper, the estimation algorithm was confirmed by comparison with the directly measured trajectory through the analysis of a 500 kN deadweight force standard machine in Korea Research Institute of Standards and Science. After the dynamic analysis of the force machine, it was modified to decrease the pendulum motion effects by accurately controlling its loading speed. As a result of the modification, the oscillating level due to the dynamic behavior of the force machine has been reduced considerably.

Keywords: Build-up system; Deadweight force machine; Pendulum motion; Tilt angle

1. Introduction

The most accurate way to produce a force is to subject deadweights of known masses to the effect of local gravitational acceleration. The mechanical structure and apparatus used to manage and control such deadweights is known as a deadweight force machine. The theoretical uncertainty of a deadweight force machine is less than 2×10^{-5} . This uncertainty has been mainly ascribed to the deadweight itself, gravitational acceleration and buoyancy correction. A number of other factors that increase the measurement uncertainty in the realization of force are still not well defined. One significant example of these factors is the motion of the deadweight. The deadweight's motion can be measured directly by using displacement sensors, but it is impossible to measure the displacement directly in some deadweight force machines because of their limited space for mounting these

sensors.

The authors have investigated deadweight motion by using a build-up system [1-4]. The build-up system consists of three identical force transducers in parallel and provides an efficient method for measuring large forces. Build-up systems have been used as large force standards at some national institutes for metrology [5-7]. In our previous work [3], we have investigated oscillating frequency of pendulum motion in a 500 kN deadweight force standard machine and proposed an IIR(infinite impulse response) filter to reduce the oscillation due to the pendulum motion. Also, we have investigated the dynamic behavior of a 100 kN deadweight force machine at the Korea Research Institute of Standards and Science (KRIS) using a build-up system [4]. We have proposed several signal processing methods to estimate trajectory of the pendulum motion, major and minor tilt angles of the elliptic pendulum motion, direction of major axis of the elliptic motion, and the rotational direction as functions of time [4].

By using the proposed estimating methods, we have investigated several deadweight force standard

[†] This paper was recommended for publication in revised form by Associate Editor Seong-Wook Hong

^{*} Corresponding author. Tel.: +82 42 868 5240, Fax.: +82 42 868 5249

E-mail address: ykpark@kriss.re.kr

© KSME & Springer 2009

machines in the world. The pendulum motion behavior of a deadweight force machine differs from other machines. This paper briefly summarizes the pendulum motions of the deadweight force machines.

Although the estimating method was proposed and applied to several force machines, its reliability has not been reported yet. To investigate the reliability, the trajectory estimated using a build-up system was compared with a directly measured trajectory from the displacement sensors. A 500 kN deadweight force machine was analyzed for this purpose, because it has suitable space to mount two displacement sensors for the direct measurement of pendulum trajectory. This paper describes the comparison in terms of correlation coefficients between the trajectories estimated using a build-up system and those measured directly.

As reported in Park and Kang [4], the relative uncertainty due to the pendulum motion is much lower than the generated force uncertainty from a deadweight force standard machine. In addition, the oscillating signal component can be reduced satisfactorily with the help of an appropriate filter [3]. Nevertheless, the dynamic motion of a deadweight force machine is a key parameter indicating how stable the machine is. Therefore, the relative uncertainty due to the pendulum motion is worth knowing although its level is very low.

The 500 kN force standard machine was modified to reduce vibration due to pendulum motion. This paper describes the reduction of the deadweight’s motion in terms of relative uncertainty due to the pendulum motion. After modification, the relative uncertainty, due to the pendulum motion, was reduced dramatically. This paper also describes the comparison of the pendulum motion’s characteristics, such as elliptic direction and frequency, before and after the modification.

2. Method of estimating pendulum motion in a deadweight force machine Section

When a force transducer system is set into a deadweight force machine, oscillating signal components from force transducers in the build-up system are strongly related to the motions of the deadweight. If a build-up system is used instead of a single force transducer, the oscillating signal component can be measured with accentuated amplitude. This is because the center of each transducer in the build-up system is offset from the deadweight’s center by several tens of

millimeters; therefore, the oscillating signal components are accentuated by the lever mechanism. The use of a build-up system provides a useful means of investigating the motion of a deadweight force machine because the oscillating components reflect the dynamic behavior of the machine.

In the build-up system of a deadweight force machine, the scale pan of the machine delivers the load to the force transducers through the spherical cap of the load button, as shown in Fig. 1. Assuming the force transducers are identical and are located exactly, and if the normal to the plane surface of the scale pan coincides with the vertical axis, the output signals measured from the force transducers must be identical, but the scale pan is usually tilted slightly [4].

$$\alpha = \tan^{-1} \left(\frac{\sqrt{3} R}{2} \frac{F_C - F_B}{r - H F_A + F_B + F_C} \right),$$

$$\beta = \tan^{-1} \left(\frac{1}{2} \frac{R}{r - H} \frac{F_B + F_C - 2F_A}{F_A + F_B + F_C} \right),$$
(1)

where α and β are tilt angles along x and y directions, respectively, H is the total height between the load button and middle platen of the build-up system, and r is the radius of the load button, as shown in Fig. 1. F_A , F_B and F_C are three reactions from three force transducers A, B, and C, respectively, and R is the radius of the circumscribed circle about the triangle of the points A, B and C represented in Fig. 2.

The pendulum motion may be modeled as an elliptic motion, which implies that

$$\alpha(t) = r_i \cos \theta \cos \omega t - r_s \sin \theta \sin \omega t,$$

$$\beta(t) = r_i \sin \theta \cos \omega t + r_s \cos \theta \sin \omega t,$$
(2)

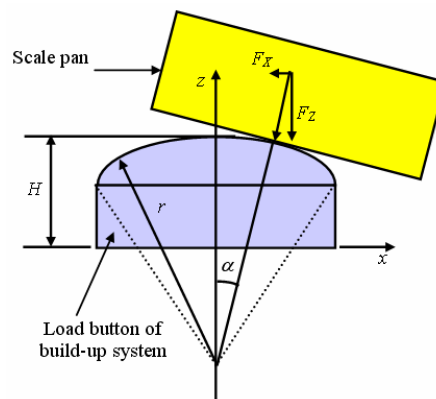

Fig. 1. Tilt angle of deadweight loading.

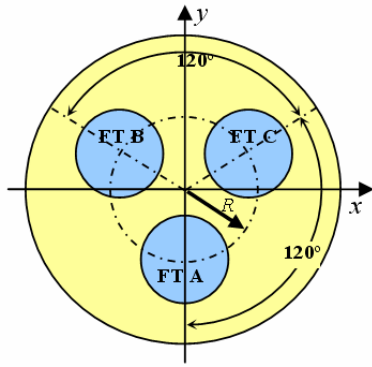

Fig. 2. Location of force transducers in a build-up system.

where r_b, r_s are, respectively, the major and minor radii of the ellipse, θ is the angle between the major axis of the ellipse and the x axis and ω is the radial frequency of the motion. r_b, r_s and θ may be functions of time. Eq. (2) can be rewritten as

$$\begin{aligned} \alpha(t) &= |\alpha(t)| \cos[\phi_\alpha(t)], \\ \beta(t) &= |\beta(t)| \cos[\phi_\beta(t)], \end{aligned} \tag{3}$$

where $|\alpha(t)|$ and $\phi_\alpha(t)$ are the complex envelope and instantaneous phase of $\alpha(t)$, and $|\beta(t)|$ and $\phi_\beta(t)$ are those of $\beta(t)$. The complex envelope and instantaneous phase can be estimated using the Hilbert transform [8].

The ratio of the complex envelopes and the instantaneous phase difference are represented as

$$\begin{aligned} \frac{|\beta|^2}{|\alpha|^2} &= \frac{(r_s/r_i)^2 + \tan^2 \theta}{1 + (r_s/r_i)^2 \tan^2 \theta}, \\ \phi_\alpha - \phi_\beta &= \tan^{-1}[(r_s/r_i) \tan \theta] + \tan^{-1}[(r_s/r_i)/\tan \theta]. \end{aligned} \tag{4}$$

By solving Eq. (4), the angle θ is estimated and the two radii are estimated by using the estimated θ as follows.

$$\begin{aligned} r_i^2 &= \frac{|\beta|^2 \sin^2 \theta - |\alpha|^2 \cos^2 \theta}{\sin^4 \theta - \cos^4 \theta}, \\ r_s^2 &= \frac{|\alpha|^2 \sin^2 \theta - |\beta|^2 \cos^2 \theta}{\sin^4 \theta - \cos^4 \theta}. \end{aligned} \tag{5}$$

Because of the pendulum motion of the force machine, some loss of force occurs due to the occurrence of a side force. The relative uncertainty due to the pendulum motion can be represented as

$$\frac{\Delta F}{F} = \frac{\text{Max}(\alpha^2 + \beta^2)}{2}, \tag{6}$$

where $\text{Max}(\alpha^2 + \beta^2)$ is the maximum tilt angle of the pendulum motion, F is the force generated by a force standard machine, and ΔF is the loss of force.

3. Experimental verification for the method of estimating pendulum motion

The experimental arrangement to measure the dynamic behavior of the force machine consists of a build-up system, two displacement sensors and a signal processing system. The build-up system was developed in-house and its capacity is 600 kN. The displacement sensors were non-contact type having a measuring range of 1 mm. The signals from the force transducers in the build-up system were amplified and sampled by a signal-conditioning amplifier. The signal-conditioning amplifier also sampled the signals from the displacement sensors. All the signals were sampled simultaneously at a sampling rate of 75 Hz and transmitted to a personal computer through a GPIB interface, 8192 data points for each signal. This implies that the total data length was 109.2 s. Fig. 3 shows the build-up system, displacement sensors and signal-processing system.

The schematic of the 500 kN deadweight force machine at the KRISS is shown in Fig. 4. The first weight, of 1,360.8 kg was constructed in the form of a frame and its upper part was used as the load platen. In the unloaded condition, 10 weights each of 4,536 kg (the lower weights) rest in conical support sockets, which are connected to the building. Nine weights, each of 453.6 kg, are supported by three threaded rods, which engage bevel seats in plates attached to the tops of the 453.6 kg weights. The lifting frame, which carries the upper or tension platen and the lower or compression platen, is suspended from the centre of a hydraulic piston located above. Both platens are independently adjustable to accommodate the size of the particular force sensor. The weight increment is fixed and cannot be varied. The machine is approximately 15 m high by 2 m wide. The weights are on the first floor of the laboratory building, the forces are applied to the calibration device on the second floor, and the hydraulic jack for lifting the weights is on the third floor. The relative uncertainty of the deadweight force standard machine was declared to be 2×10^{-5} .

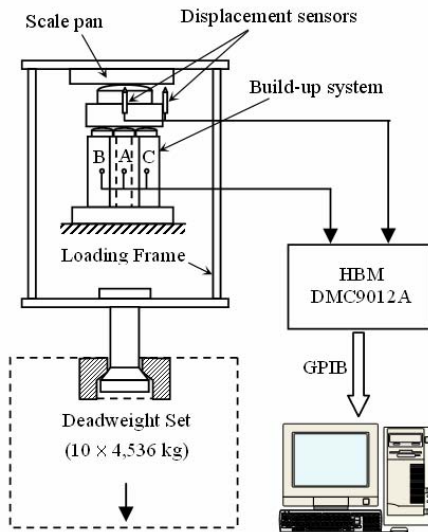

Fig. 3. Experimental arrangement.

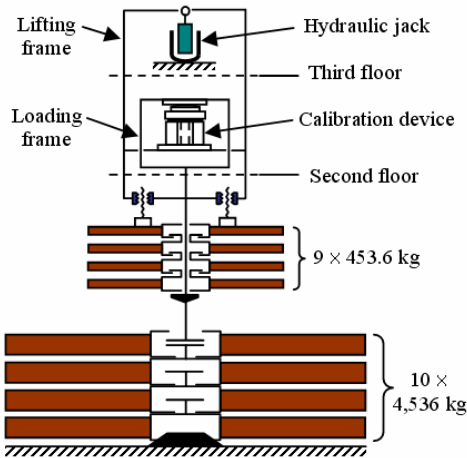

Fig. 4. Schematic illustration of the 500 kN deadweight force machine.

In the experiment, only the larger deadweights were used to generate loads. Fig. 5 shows the trajectory of the pendulum motion when five deadweights were loaded. Fig. 5(a) is the trajectory estimated from the force signals in the build-up system. To calculate the displacement trajectory, we estimated the tilt angle using Eq. (1), then converted this to the displacement. Fig. 5(b) is the trajectory directly measured from the displacement sensors. The two figures are very similar and the correlation coefficient between the two trajectories is 0.9870, which is the mean of the x directional and y directional correlation coefficients.

Table 1. Correlation coefficients between trajectories estimated using build-up system and measured directly.

No. of weights	Correlation Coefficient	
	Along x axis	Along y axis
1	1.0000	0.9962
2	1.0000	0.9981
5	0.9999	0.9740
7	0.9999	0.9202
10	1.0000	1.0000

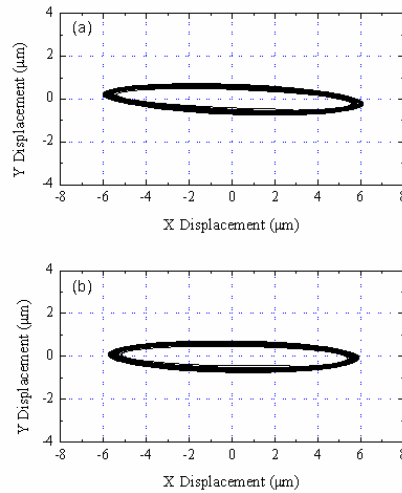

Fig. 5. Comparison of the trajectory of the pendulum motion: (a) estimated, (b) directly measured.

Table 1 represents correlation coefficients between estimated and directly measured trajectories for different numbers of load weights. For all loading conditions, correlation coefficients of x directional motion are slightly higher than those of y directional motion. This is because the elliptic motion appears to be along the x axis, hence the magnitude of x directional motion is larger than that of y direction. The correlation coefficients when seven deadweights were loaded are lower than other ones, because the motion level is lowest at the loading condition. Due to high correlation between the estimated and measured trajectories, we confirmed the confidence level of the estimation method.

4. Reduction of the deadweight motion

To reduce the deadweight motion, the 500 kN force standard machine was modified. Before the modification, the loading frame of the force machine moved

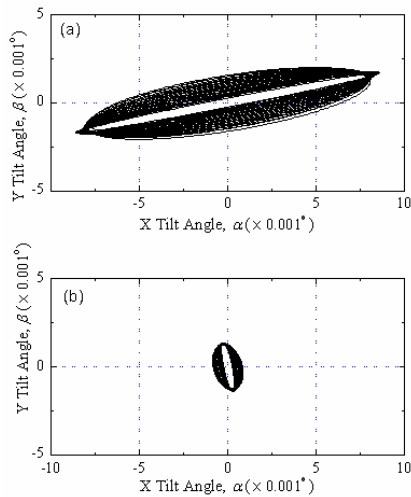

Fig. 6. Pendulum motion trajectory before and after modification: (a) before modification, (b) after modification.

up with a constant speed even when the loading frame contacted a weight to load. Therefore, the contact causes an impact that leads to vibration in the force machine, such as the pendulum motion. After the modification, the machine controls the speed of the loading frame and decreases speed when it contacts a weight. In addition, the operation of the force machine was fully automated.

Fig. 6 represents trajectories of deadweight pendulum motion of the force machine when two deadweights were loaded. Fig. 6(a) and (b) are the trajectories before and after modification, respectively. From the figure, it can be clearly seen that the direction of the pendulum motion was changed and the level of the pendulum motion was reduced. The rest of this chapter will describe the effects of modification in terms of elliptic direction, frequency and relative uncertainty due to pendulum motion.

Fig. 7 shows the axis angle of the elliptic motion for different numbers of load weights before modification. The angles are estimated as the mean values over 100 seconds. In the figure, the error bars denote the standard deviation of the directions during the 100 seconds. For all the five loading conditions, the elliptic direction is near 0° , which means the elliptic motion appears to be along the x axis. The minimum direction is -2.3° if five weights are loaded and the maximum direction is 18.7° if ten weights are loaded. The standard deviation is less than 1.5° for all loading conditions, which means the direction of the ellipse is time invariant.

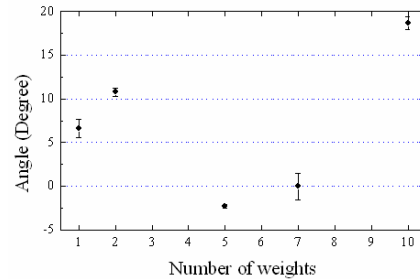

Fig. 7. Direction of pendulum motion of the 500 kN dead-weight force machine at different loads before modification.

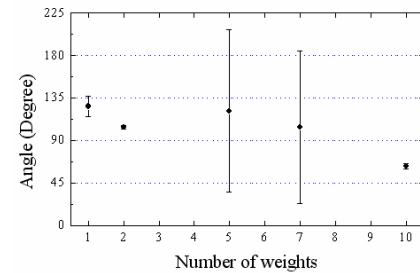

Fig. 8. Direction of pendulum motion of the 500 kN dead-weight force machine at different loads after modification.

Fig. 8 shows the direction of the elliptic motion after the deadweight force machine was modified. The error bars represent the standard deviations of the directions. The directions and the standard deviations were estimated over a 100 second period. Comparing this figure with Fig. 7, it can be seen that the elliptic direction changed from x axis motion to y axis motion. When five and seven weights are loaded, the standard deviations are very large. This means that the pendulum motion no longer has any specific direction; therefore, it has wide distribution. This is because the magnitude of the swing motion is considerably reduced by the modification of the force machine.

Table 2 represents frequencies of pendulum motions before and after the force machine was modified. After modification, the frequencies when the numbers of weights are five and seven cannot be calculated because of low oscillating level. It can be seen that the frequency decreases slightly after modification. However, the amount the frequency decrease is within several counts of frequency resolution; therefore, it can be negligible.

The relative uncertainty due to pendulum motion was estimated by using Eq. (6). Although the level of the relative uncertainty is much lower than the declared relative uncertainty of the force standard

Table 2. Frequency of pendulum motion in the 500 kN force machine before and after modification.

No. of weights	Frequency (Hz)	
	Before modification	After modification
1	0.229	0.226
2	0.220	0.220
5	0.211	-
7	0.201	-
10	0.192	0.189

Table 3. Relative uncertainty due to the pendulum motion in the 500 kN force machine before and after modification.

No. of weights	Relative uncertainty	
	Before modification	After modification
1	1.71×10^{-8}	2.19×10^{-10}
2	1.23×10^{-8}	3.57×10^{-10}
5	1.11×10^{-9}	1.80×10^{-13}
7	2.01×10^{-10}	5.38×10^{-12}
10	2.38×10^{-9}	1.13×10^{-12}

machine, 2×10^{-5} , the analysis of the uncertainty is valuable to check the stability of the force standard machine. Table 3 shows the relative uncertainty before and after the force standard machine was modified.

Before the modification, the relative uncertainty decreases overall as the loaded weights increase, except when 10 weights are loaded. The uncertainty is the lowest when seven weights are loaded, when the magnitude of the swing motion is least. After the modification, the relative uncertainty is reduced to less than 0.01 times that of the force machine before modification. With the reduced uncertainty, it can be easily seen that the deadweight force machine becomes much more stable.

5. Discussion of deadweight pendulum motion

Fig. 9 describes the elliptic motion of the deadweights when ten weights were loaded. Fig. 9(a), (b) and (c) are the trajectory of the tilt angle, direction of the elliptic motion and the major and minor tilt angles, respectively, over about 100 seconds. As shown in Fig. 9(b), the direction of the ellipse slowly increases from approximately 14° to approximately 19° as time elapses. This figure shows that the direction of elliptic motion is concentrated in a narrow range of angle. Fig. 9(c) shows that the minor tilt angle is conserved with

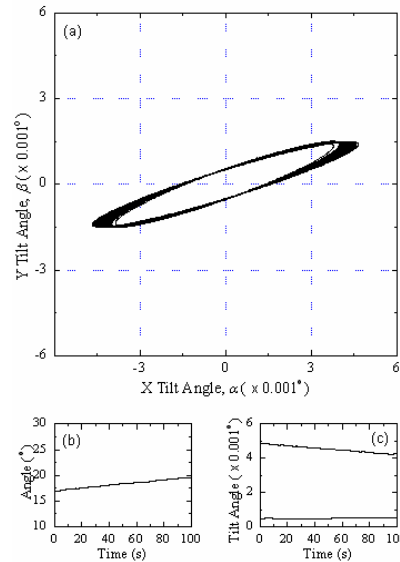

Fig. 9. Pendulum motion of the 500 kN deadweight force machine when 10 weights are loaded: (a) trajectory, (b) direction of the major axis, (c) major and minor tilt angles.

time and that the major tilt angle slowly decreases with time. The rotational direction is clockwise over the entire period of interest.

The pendulum behavior of the 500 kN deadweight force standard machine is quite different from that of the 100 kN deadweight force standard machine in KRISS [9]. The direction of the elliptic motion in the 100 kN force machine is not concentrated in a narrow range of angle. The elliptic direction as well as the rotational direction changed with time in the 100 kN force machine. Fig. 10 shows a typical trajectory of the pendulum motion in which the direction of elliptic motion is time variant. For details of the dynamic behavior of the 100 kN force machine, please refer to Park and Kang [4].

We have examined several deadweight force standard machines in the world. Table 4 represents a brief summary of the structure and pendulum motion's characteristics of the deadweight force standard machines. In the table, the pendulum motion is classified into two categories according to the time variance of elliptic direction. Among the five deadweight force standard machines, three showed time variant elliptic direction like Fig. 10 and the others showed time invariant behavior like Fig. 9. Even for a rough classification of the pendulum motion, it is not easy to find any distinguishing parameters of the force machines between the two categories.

Table 4. Summary of structure and pendulum motion characteristics of deadweight force machines.

Deadweight force machine	No. of columns in main frame	No. of columns in loading frame	Deadweight loading type	Change of elliptic direction
Korea 100 kN	3	3	Binary combination	Yes
Germany 100 kN	2	3	Sequential	Yes
Japan 540 kN	4	2	Sequential	Yes
Korea 500 kN	4	4	Sequential	No
Germany 1 MN	3	3	Binary combination	No

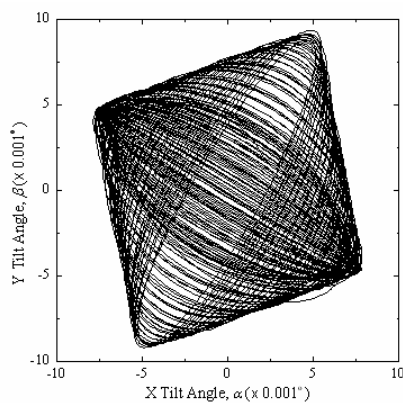

Fig. 10. Pendulum motion of the 100 kN deadweight force machine in which the elliptic direction is time variant.

From Fig. 6, one can easily see that the direction of pendulum motion is different between the trajectories before and after modification of the 500 kN deadweight force machine although the trajectories were measured for the same force machine. It can be concluded that the pendulum motion characteristics are highly dependent on the initial condition to activate the motion.

6. Conclusions

We experimentally analyzed pendulum motion of deadweight force machine by using a build-up system. The analysis is summarized as follows.

- (1) We verified the estimation method of deadweight pendulum motion by analyzing dynamic behavior of the deadweights in a 500 kN force standard

machine. The estimated trajectory of the pendulum's motion using the build-up system showed good agreement with the trajectory directly measured using displacement sensors.

- (2) The 500 kN deadweight force standard machine was modified to reduce its dynamic motion by decreasing the speed of the loading frame when it contacts a weight. Using the proposed method, we confirmed that the pendulum motion level decreases dramatically after the modification.
- (3) Mechanical structure and dynamic behavior of several deadweight force machines were summarized. The relation between the estimated dynamic behavior and the structure of a deadweight force standard machine has not been fully understood. The pendulum motion characteristics are dependent on the initial condition to activate the motion.

References

- [1] D. I. Kang and B. D. Lim, Analysis of deadweight oscillation in a deadweight force machine using a build-up system, *Experimental Mechanics*, 40 (2000) 83-89.
- [2] D. I. Kang and B. D. Lim, Determination of the averaging time for precision calibration of a build-up system in a deadweight force machine, *Measurement*, 19 (1996) 217-227.
- [3] Y. K. Park and D. I. Kang, Oscillating signal components of a deadweight force standard machine and reduction techniques, *Measurement Science & Technology*, 10 (1999) 748-754.
- [4] Y. K. Park and D. I. Kang, Pendulum motion of a deadweight force-standard machine, *Measurement Science & Technology*, 11 (2000) 1766-1771.
- [5] H. Wieringa, Design of a 1.65 MN and 4.95 MN transfer standard based on the build-up procedure, *Proc. of 10th IMEKO TC-3 Conference*, Kobe, Japan (1984) 67-77.
- [6] J. Man, Establishment of force standards up to 4.5 MN based on a build-up system at NMIA, *Proc. of APMF2005*, Jeju, Korea (2005) 45-51.
- [7] Y. K. Park and D. I. Kang, Build-up force-measuring system and its application, *MAPAN-Journal of Metrology Society of India*, 20 (2005) 223-229.
- [8] A. V. Oppenheim and R. W. Schaffer, *Discrete-time Signal Processing*, Prentice Hall, New Jersey, USA, (1989).
- [9] Y. K. Park, M. S. Kim, J. H. Kim, D. I. Kang and H.

K. Song, 100 kN deadweight force standard machine and evaluation, *J. of Mechanical Science and Technology*, 20 (7) (2006) 961-971.



Yon-Kyu Park received his B.S., M.S. and Ph.D. in Mechanical Engineering from KAIST, Korea, in 1991, 1993 and 1998, respectively. Dr. Park is currently a Principal Research Scientist of Korea Research Institute of Standards and Science (KRISS) in Korea. His research interests include standards of force and torque, mechanical sensors, and metrology in human-mechanics.